

EC10-4PT RTD Module

User Manual

Thank you for using Emerson programmable logic controller (PLC). Before using the EC10 series PLC product, please carefully read this booklet so as to better understand it, fully use it, and ensure safety.

1 Port Description

1.1 Port

The extension port and user port of EC10-4PT are both protected by a cover, as shown in Figure 1-1.

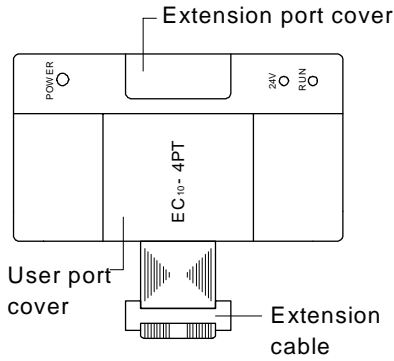

Figure 1-1 EC10-4PT appearance

Removing the covers reveals the extension port and user port, as shown in Figure 1-2.

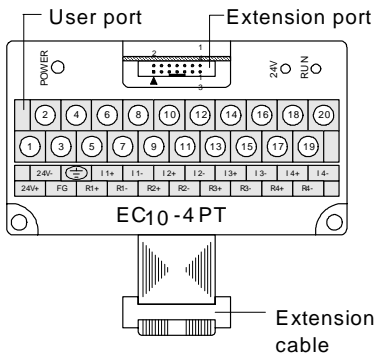

Figure 1-2 EC10-4PT ports

The extension cable connects EC10-4PT to the system, while the extension port connects EC10-4PT to another extension module of the system. For details on connection, see 1.2 Connecting Into System.

The user port of EC10-4PT is described in Table 1-1.

Table 1-1 User port description

Terminal	Name	Description
1	24V+	Analog power supply 24V+
2	24V-	Analog power supply 24V-
3	FG	Shielding ground
4	GND	GND
5, 9, 13, 17	R1+	Positive thermal-resistor signal input of CH1 ~ CH4
6, 10, 14, 18	I1+	Auxiliary positive thermal-resistor signal input of CH1 ~ CH4
7, 11, 15, 19	R1-	Negative thermal-resistor signal input of CH1 ~ CH4
8, 12, 16, 20	I1-	Auxiliary negative thermal-resistor signal input of CH1 ~ CH4

1.2 Connecting Into System

Through the extension cable, you can connect EC10-4PT to EC10 series basic module or other extension modules. While through the extension port, you can connect other EC10 series extension modules to

EC20-4PT. See Figure 1-3.

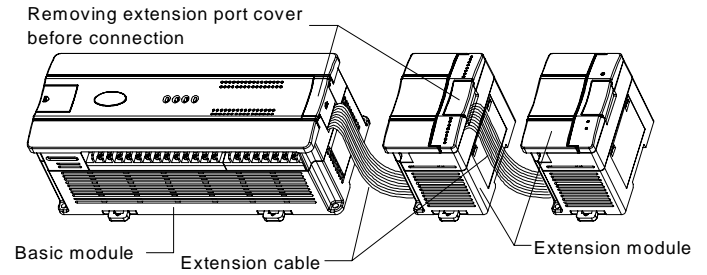

Figure 1-3 Connecting into system

1.3 Wiring

Figure 1-4 shows the wiring of the user port.

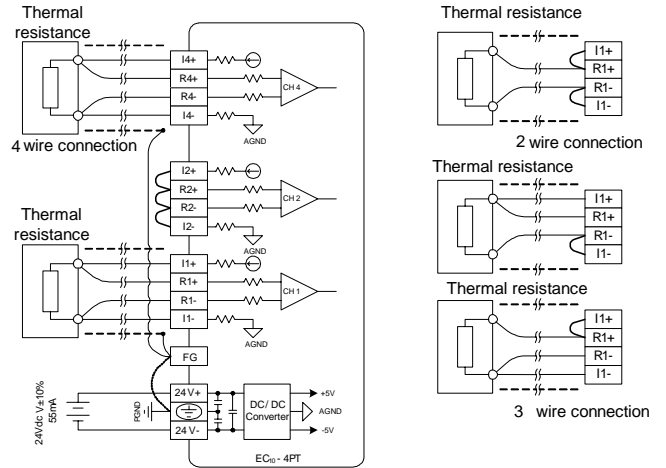

Figure 1-4 Wiring of EC10-4PT user port

The circled 1~5 stands for the five points to be observed during wiring.

1. Use shielded cables to input the thermal-resistor signal. Route them separate from power cable or any cable that may generate EMI. The requirements on the thermal-resistor signal input cable also include:
 - 1) The thermal resistance sensor (Pt100, Cu100 or Cu50) can use 2-, 3-, or 4-wire system, the ascending measurement precisions. When the cable is longer than 10m, the 4-wire system is recommended.
 - 2) To reduce the measurement error and avoid EMI, the cable should be shorter than 100 meters. The measurement error is due to the connecting cable's impedance, and the error may differ with different channels even within the same module. Consequently we need to adjust the characteristics of each channel. See 3 Setting Characteristics for details.
2. If strong EMI exists, connect the shielding ground FG to the PG terminal.
3. Properly ground module PG terminal.
4. The basic module's 24Vdc auxiliary output power or other qualified power supplies can be used as the power source for the analog circuit.
5. Short the unused channel as shown in the figure.

2 Indices

2.1 Power Supply

Table 2-1 Power supply

Item	Specification
Analog circuit	24Vdc (-15% ~ +20%), maximum allowable ripple voltage 5%
	55mA (from basic module or external power supply)
Digital circuit	5Vdc, 72mA (from basic module)

2.2 Performance

Table 2-2 Performance

Item	Specification			
	Celcius (°C)		Fahrenheit (°F)	
Input signal	Thermal resistance type: Pt100, Cu100 and Cu50 Channel No.: 4			
Conversion speed	(15 ± 2%) ms × 4 channel (no conversion for unused channels)			
Rated temperature range	Pt100	-150°C ~ 600°C	Pt100	-238°F ~ 1112°F
	Cu100	-30°C ~ 120°C	Cu100	-22°F ~ 248°F
	Cu50	-30°C ~ 120°C	Cu50	-22°F ~ 248°F
Digital output	12-bit A/D conversion. The temperature readings are stored as 16-bit two's complement			
	Pt100	-1500 ~ 6000	Pt100	-2380 ~ 11120
	Cu100	-300 ~ 1200	Cu100	-220 ~ 2480
	Cu50	-300 ~ 1200	Cu50	-220 ~ 2480
Lowest resolution	Pt100	0.2°C	Pt100	0.36°F
	Cu100	0.2°C	Cu100	0.36°F
	Cu50	0.2°C	Cu50	0.36°F
Precision	±1% of full range			
Isolation	Between analog circuit and digital circuit: photocoupler.			
	Between analog circuit and input 24Vdc power: internal isolation. Between analog channels: none			

2.3 Buffer Memory

EC10-4PT exchanges data with the basic module through Buffer Memory (BFM). After EC10-4PT is set through the host software, the basic module will write data into EC10-4PT BFM to set the state of EC10-4PT, and display the data from EC10-4PT on the host software interface. See figures 4-1 ~ 4-4.

Table 2-3 describes the contents of BFM of EC10-4PT.

Table 2-3 BFM content

BFM	Content	Default	Property
#100	Average temperature of CH1		R
#101	Average temperature of CH2		R
#102	Average temperature of CH3		R
#103	Average temperature of CH4		R
#200	Present temperature of CH1		R
#201	Present temperature of CH2		R
#202	Present temperature of CH3		R
#203	Present temperature of CH4		R
#300	Error state word 1		R
#301	Error state word 2		R
#600	Thermal resistance type and temperature mode select 0	H0000	RW
#700	Sampling times for average of CH1	8	RW
#701	Sampling times for average of CH2	8	RW
#702	Sampling times for average of CH3	8	RW
#703	Sampling times for average of CH4	8	RW
#800	Characteristic setting confirmation command 0	H0000	RW
#900	CH1-D0	0	RW
#901	CH1-A0	0	RW
#902	CH1-D1	6000	RW
#903	CH1-A1	6000	RW
#904	CH2-D0	0	RW
#905	CH2-A0	0	RW
#906	CH2-D1	6000	RW
#907	CH2-A1	6000	RW
#908	CH3-D0	0	RW
#909	CH3-A0	0	RW
#910	CH3-D1	6000	RW
#911	CH3-A1	6000	RW
#912	CH4-D0	0	RW
#913	CH4-A0	0	RW
#914	CH4-D1	6000	RW
#915	CH4-A1	6000	RW
#4094	Module software version	0x1000	R

BFM	Content	Default	Property
#4095	Module ID	H5041	R

Explanation:

- CH1 stands for channel 1; CH2, channel 2; CH3, channel 3, and so on.
- Property explanation: R means read only. An R element cannot be written. RW means read and write. Reading from a non-existent element will get 0.
- BFM#200 ~ BFM#203: present temperature. This value uses the unit of 0.1°C or 0.1°F (as determined by BFM#600). For example, 1000 means 100°C (or 100°F, as determined by BFM#600 and BFM#601). The average temperature is stored in BFM#100 ~ BFM#103.
- BFM#300: Error state word 1. See Table 2-4 for its error state information.

Table 2-4 BFM#300 error state information

Bit status of BFM#300	ON (1)	OFF (0)
b0: system error	b1 or b2 is 1 (A/D conversion of all channels stopped)	Normal
b1: channel characteristic setting error	Channel characteristics setting error in BFM	Channel characteristics setting normal
b2: power supply failure	24Vdc power failure	Power supply normal
b3: hardware fault	Fault with A/D convertor or other hardware	Hardware normal
b4 ~ b9: reserved	-	-
b10: digital range error	A/D conversion digital output exceeds the range of -2048 ~ 2047	Digital output value normal
b11: average sampling times setting error	Setting outside normal range (in this case, the previous valid setting will be restored)	Setting within normal range: 1~256
b12 ~ b15: reserved	-	-

- See Table 2-5 for the state information of BFM#301.

Table 2-5 BFM#301 state information

Channel	Bit	1	0
1	b0	CH1 temperature below lower limit	CH1 normal
	b1	CH1 temperature above upper limit	CH1 normal
2	b2	CH2 temperature below lower limit	CH2 normal
	b3	CH2 temperature above upper limit	CH2 normal
3	b4	CH3 temperature below lower limit	CH3 normal
	b5	CH3 temperature above upper limit	CH3 normal
4	b6	CH4 temperature below lower limit	CH4 normal
	b7	CH4 temperature above upper limit	CH4 normal
Reserved	b8 ~ b15	-	-

- BFM#600: channel mode setting, used to set the working modes of CH1 ~ CH4. See Figure 2-1 for their correspondence.

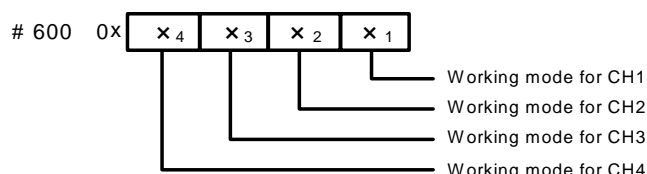

Figure 2-1 Mode setting element vs. channel

See Table 2-6 for the meaning of "X". Each channel's conversion time is 15ms. When a channel is closed, the channel will not perform A/D conversion, reducing the total conversion time.

Table 2-6 Meanings of X in the format

SN	Value of X	Corresponding mode
1	0	Pt100 thermal resistance, digital signal unit: 0.1°C
2	1	Pt100 thermal resistance, digital signal unit: 0.1°F
3	2	Cu100 thermal resistance, digital signal unit: 0.1°C
4	3	Cu100 thermal resistance, digital signal unit: 0.1°F
5	4	Cu50 thermal resistance, digital signal unit: 0.1°C

SN	Value of X	Corresponding mode
6	5	Cu50 thermal resistance, digital signal unit: 0.1°F
7	6 ~ F	Channels closed

7. BFM#700 ~ BFM#703: average sampling times setting. Range: 1 ~ 256. If the setting is outside this range, the default value 8 will be used.

8. BFM#900 ~ BFM#915: channel characteristics settings, which are set using two-point method. D0 and D1, in 0.1°C unit, represent the channel's digital outputs, while A0 and A1, also in 0.1°C unit, the actual temperature inputs. Each channel occupies 4 words.

Note: the characteristic parameters are all in 0.1°C unit. As for those parameters in Fahrenheit unit, convert them into Celsius unit through the following format before writing them into the characteristic setting:

$$\text{Celsius} = 5/9 \times (\text{Fahrenheit} - 32)$$

11. BFM#4094: module software version, displayed automatically as **Module Version** in **EC10-4PT Configuration** dialogue box of the host software, as shown in Figure 4-1.

12. BFM#4095: module ID. The ID of EC10-4PT is 0x5041. The user program in PLC can use this ID to identify the module before transceiving data.

3 Setting Characteristics

The input channel characteristics of EC10-4PT are the user adjustable linear relationship between the channel's analog input A and digital output D. Each channel can be considered as the model shown in Figure 3-1. As it is of linear characteristic, the channel characteristic can be defined by two points: P0 (A0, D0) and P1 (A1, D1), where D0 is the channel digital output corresponding to analog input A0, and D1 is the channel digital output corresponding to analog input A1.

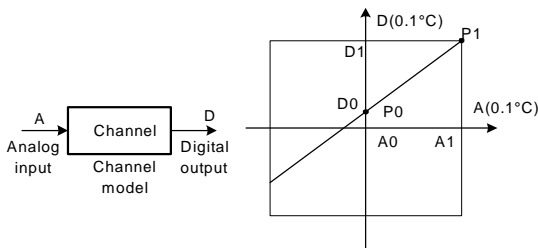

Figure 3-1 EC10-4PT channel characteristic

The measurement error is caused by the impedance of the connecting cable. You can correct it by setting the channel characteristic.

To simplify the operation process without affecting functions, A0 and A1 are respectively fixed to the analog 0 and 6000 (in 0.1°C unit) in the current mode. That is to say, in Figure 3-1, A0 is 0.0°C and A1 is 600°C, which are not adjustable.

If you set the channel mode (BFM#600) without changing D0 and D1 of the corresponding channel, the channel characteristic vs. mode should be as shown in Figure 3-2.

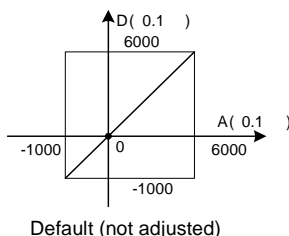

Figure 3-2 Characteristics vs. mode without changing D0 and D1

Note: When the mode is set to 1 or 3, or say, when the output is in 0.1°F unit, the temperature data read from the output data zone (BFM#100~#103, #200~#203) will be in 0.1°F unit, but the data in the channel characteristics setting zone (BFM#900~#915) will still be in 0.1°C unit. That is to say, the data in the channel characteristics setting zone (BFM#900~#915) can only be in 0.1°C unit. Keep this in mind when changing the values of D0 and D1.

You can change the characteristics by changing D0 and D1. The setting range of D0 is -1000 ~ +1000 (0.1°C); D1, 5000~7000 (0.1°C). If the

setting is outside this range, EC10-4PT will not accept it, but maintain the original valid setting. Figure 3-3 provides for your reference an example of characteristics adjustment when the measured value is 5°C (41°F) higher the actual value.

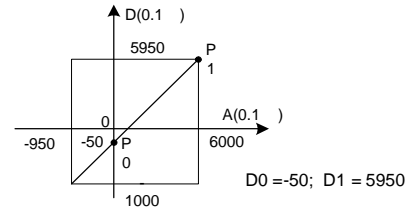

Figure 3-3 Change characteristic

4 Application Example

4.1 Basic Application

Example: The EC10-4PT module address is 0. Connect CH1 to Pt100 thermal resistance to output Celsius data, CH2 to Cu100 thermal resistance to output Celsius data, and CH3 to Cu50 to output Fahrenheit data and close CH4. Set the average sampling times to 4, and use data registers D1, D2 and D3 to receive the average value. See Figure 4-1 ~ Figure 4-4 for the setting method. For further details, see *EC20/EC10 Series PLC Programming Manual*.



Figure 4-1 Setting CH1



Figure 4-2 Setting CH2



Figure 4-3 Setting CH3



Figure 4-4 Changing characteristic

4.2 Changing Characteristics

Example: The EC10-4PT module address is 0. Connect CH1 to Pt100 thermal resistance to output Celsius data, CH2 to Cu100 thermal resistance to output Celsius data, CH3 to Cu50 to output Fahrenheit data and close CH4. They all have the characteristics shown in Figure 3-3 (the EC10-4PT measured temperature is 5°C/41°F higher than the actual one). In this case, CH1, 2 and 3 will output respectively 6000, 1200 and 2480 at the actual measured temperature of 600°C, 120°C and 248°F. Use data registers D1, D2 and D3 to receive the average value. The channel characteristic adjusting method is shown in Figure 4-4. Note that the unit is Celsius, and the adjusting range is within ±1000 (±100°C).

5 Operation Inspection

5.1 Routine Inspection

1. Check that the analog input wiring meets the requirement (see 2.4 *Wiring*).
2. Check that the extension cable is properly inserted into the extension port of the basic module.
3. Check that the 5V and 24V power supplies are not overloaded. Note that the digital circuit of EC10-4PT is powered by the basic module through the extension cable.
4. Check the application, and make sure the operation method and parameter range are correct.
5. Set the EC10 basic module to RUN state.

5.2 Inspection Upon Fault

In case of abnormality, check the following items:

The status of the POWER indicator

ON: the extension cable is properly connected;

OFF: check the extension cable connection and the basic module.

The wiring of analog input

The status of the 24V indicator

ON: 24Vdc power supply normal;

OFF: 24Vdc power supply faulty, or EC10-4PT faulty.

The RUN indicator

Flashing quickly: EC10-4PT normal.

OFF or flashing slowly: Check the **Error Status** in **EC10-4PT Configuration** dialogue box through the host software.

Notice

1. The warranty range is confined to the PLC only.
2. **Warranty period is 18 months**, within which period Emerson Network Power conducts free maintenance and repairing to the PLC that has any fault or damage under the normal operation conditions.
3. **The start time of warranty period is the delivery date of the product**, of which the product SN is the sole basis of judgment. PLC without a product SN shall be regarded as out of warranty.
4. Even within 18 months, maintenance will also be charged in the following situations:
 - Damages incurred to the PLC due to mis-operations, which are not in compliance with the User Manual;
 - Damages incurred to the PLC due to fire, flood, abnormal voltage, etc;
 - Damages incurred to the PLC due to the improper use of PLC functions.
5. The service fee will be charged according to the actual costs. If there is any contract, the contract prevails.
6. Please keep this paper and show this paper to the maintenance unit when the product needs to be repaired.
7. If you have any question, please contact the distributor or our company directly.

ENP Services China

Emerson Network Power Co., Ltd.

Address: No.1 Kefa Rd., Science & Industry Park, Nanshan District 518057, Shenzhen China

Homepage: www.emersonnetworkpower.com.cn

E-mail: support@emersonnetwork.com.cn

Version V1.0

Revision date August 24, 2006

BOM 31011371

Copyright © 2006 by Emerson Network Power Co., Ltd.

All rights reserved. The contents in this document are subject to change without notice.