

EC10-4TC Thermocouple Module

User Manual

Thank you for using Emerson programmable logic controller (PLC). Before using the EC10 series PLC product, please carefully read this booklet so as to better understand it, fully use it, and ensure safety.

1 Port Description

1.1 Port

The extension port and user port of EC10-4TC are both protected by a cover, as shown in Figure 1-1. Removing the covers reveals the extension port and user port, as shown in Figure 1-2.

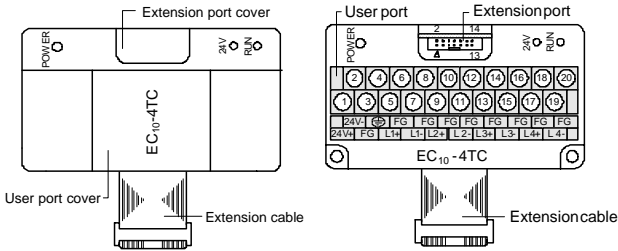

Figure 1-1 EC10-4TC appearance Figure 1-2 EC10-4TC ports

The extension cable connects EC10-4TC to the system, while the extension port connects EC10-4TC to another extension module of the system. For details on connection, see 1.2 Connecting Into System.

The user port of EC10-4TC is described in Table 1-1.

Table 1-1 User port description

Terminal	Name	Description
1	24V+	Analog power supply 24V+
2	24V-	Analog power supply 24V-
3	•	NC
4	⊕	GND
5, 9, 13, 17	L1+, L2+, L3+, L4+	Positive poles of thermocouples for channels 1 to 4
7, 11, 15, 19	L1-, L2-, L3-, L4-	Negative poles of thermocouples for channels 1 to 4
6, 8, 10, 12, 14, 16, 18, 20	FG	Shielding GND

1.2 Connecting Into System

Through the extension cable, you can connect EC10-4TC to EC10 series basic module or other extension modules. While through the extension port, you can connect other EC10 series extension modules to EC10-4TC. See Figure 1-3.

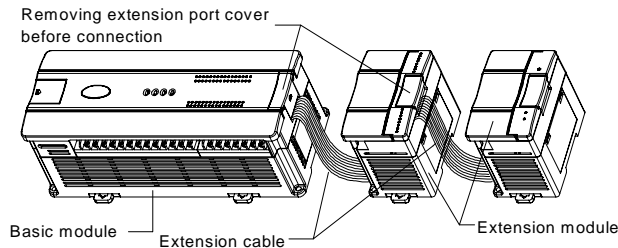

Figure 1-3 Connecting into system

1.3 Wiring

The wiring of user port is shown in Figure 1-4.

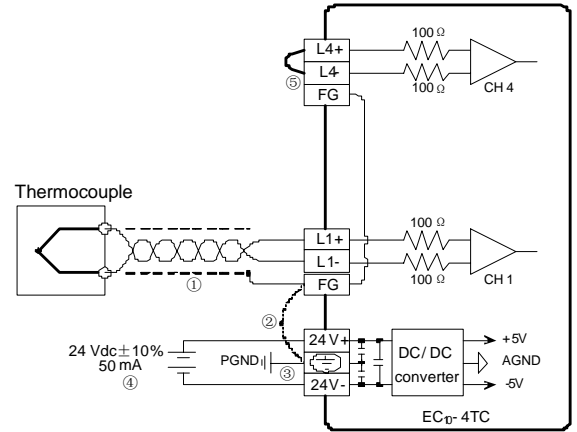

Figure 1-4 Wiring of EC10-4TC user port

The circled 1 ~ 6 stands for the six points to be observed during wiring:

1. Thermocouple signals are connected through screen compensation cables, which should be routed separate from power cables or other EMI-generating cables. Long compensation cables are susceptible to EMI, so the compensation cables should be advisably shorter than 100m. Compensation cable has impedance, which can cause measurement error. This problem can be addressed through characteristics adjustment. For details, see 3 Setting Characteristics.
2. If strong EMI exists, connect the FG and PG terminals together.
3. Properly ground the module's PG terminal.
4. The basic module's 24Vdc auxiliary power or any qualified external power supply can be used to feed the module's analog circuit.
5. Short the positive and negative terminals of unused channels to avoid detecting error data from that channel.

2 Indices

2.1 Power Supply

Table 2-1 Power supply

Item	Description
Analog circuit	24Vdc (-15%~20%), maximum allowable ripple voltage: 5%, 50mA (from the basic module or external power supply)
Digital circuit	5Vdc, 72mA (from basic module)

2.2 Performance

Table 2-2 Performance

Item	Index			
	Celsius (°C)		Fahrenheit (°F)	
Input signal	Thermocouple: type K, J, E, N, T, R or S (all accessible to each channel), 4 channels			
Conversion speed	(240ms±2%)ms × 4 channels (no conversion for unused channels)			
Rated temperature range	Type K	-100°C~1200°C	Type K	-148°F ~ +2192°F
	Type J	-100°C~1000°C	Type J	-148°F ~ +1832°F
	Type E	-100°C~1000°C	Type E	-148°F ~ +1832°F
	Type N	-100°C~1200°C	Type N	-148°F ~ +2192°F
	Type T	-200°C ~ +400°C	Type T	-328°F ~ +752°F
	Type R	0°C ~ 1600°C	Type R	32°F ~ 2912°F
	Type S	0°C ~ 1600°C	Type S	32°F ~ 2912°F
Digital output	12-digit AD conversion, 16-digit complement for storage			
	Type K	-1000 ~ +12000	Type K	-1480 ~ +21920
	Type J	-1000 ~ +10000	Type J	-1480 ~ +18320
	Type E	-1000 ~ +10000	Type E	-1480 ~ +18320
	Type N	-1000 ~ +12000	Type N	-1480 ~ +21920
	Type T	-2000 ~ +4000	Type T	-3280 ~ +7520
	Type R	0 ~ 16000	Type R	320 ~ 29120
	Type S	0 ~ 16000	Type S	320 ~ 29120
Lowest resolution	Type K	0.3°C	Type K	0.54°F
	Type J	0.2°C	Type J	0.36°F
	Type E	0.3°C	Type E	0.54°F
	Type N	0.3°C	Type N	0.54°F
	Type T	0.2°C	Type T	0.36°F

Item	Index			
	Celsius(°C)		Fahrenheit (°F)	
Lowest resolution	Type R	0.5°C	Type R	0.9°F
	Type S	0.5°C	Type S	0.9°F
Accuracy	± (0.5% full range+1°C), water freezing point: 0°C/32°F			
Isolation	Between analog circuit and digital circuit: photocoupler.			
	Between analog circuit and input 24Vdc power: internal isolation. Between analog channels: none			

2.3 Buffer Memory

EC10-4TC exchanges data with the basic module through Buffer Memory (BFM). After EC10-4TC is set through the host software, the basic module will write data into EC10-4TC BFM to set the state of EC10-4TC, and display the data from EC10-4TC on the host software interface. See figures 4-1 ~ 4-8.

Table 2-3 describes the contents of the BFM of EC10-4TC.

Table 2-3 BFM contents

BFM	Content	Default	Property
#100 ~ #103	Average temperature of CH1~CH4		R
#200 ~ #203	Current temperature of CH1~CH4		R
#300	Error status word 0		R
#301	Error status word 1		R
#600	Channel mode word	0x0000	RW
#700 ~ #703	Sampling times respectively for averages of CH1 ~ CH3	8	RW
#900	CH1-D0	0 (input mode 0)	RW
#901	CH1-A0	0 (input mode 0)	RW
#902	CH1-D1	12000 (input mode 0)	RW
#903	CH1-A1	12000 (input mode 0)	RW
#904	CH2-D0	0 (input mode 0)	RW
#905	CH2-A0	0 (input mode 0)	RW
#906	CH2-D1	12000 (input mode 0)	RW
#907	CH2-A1	12000 (input mode 0)	RW
#908	CH3-D0	0 (input mode 0)	RW
#909	CH3-A0	0 (input mode 0)	RW
#910	CH3-D1	12000 (input mode 0)	RW
#911	CH3-A1	12000 (input mode 0)	RW
#912	CH4-D0	0 (input mode 0)	RW
#913	CH4-A0	0 (input mode 0)	RW
#914	CH4-D1	12000 (input mode 0)	RW
#915	CH4-A1	12000 (input mode 0)	RW
#3000	Cold end temperature	For test	R
#4094	Module software version	0x1000	R
#4095	Module ID	0x4041	R

Note:

- CH1 stands for channel 1; CH2, channel 2; CH3, channel 3, and so on.
- Property explanation: R means read only. An R element cannot be written. RW means read and write. Reading from a non-existent element will get 0.
- BFM#200 ~ BFM#203: current temperature. Unit: 0.1°C/°F (depending on the value of BFM#600). The average value are stored in BFM#100-BFM#103.
- BFM#300 error status information is shown in Table 2-4.

Table 2-4 BFM#300 status information

Bit status of BFM#300	ON (1)	OFF (0)
b0: error	b1 or b2 is ON, AD conversion of all channels stopped	No error
b2: power failure	24Vdc power supply failed	Power supply normal
b3: hardware fault	AD converter or other hardware faulty	Hardware normal
b10: digital range error	Digital output after AD conversion outside the range of -2048 ~ 2047	Digital output normal
b12 ~ b15: reserved		

5. BFM#301 error status information is shown in Table 2-5.

Table 2-5 BFM#301 status information

Channel	Bit	ON (1)	OFF (0)
1	b0	CH1 temperature lower than lower limit	CH1 normal
	b1	CH1 temperature higher than upper limit	CH1 normal
2	b2	CH2 temperature lower than lower limit	CH2 normal
	b3	CH2 temperature higher than upper limit	CH2 normal
3	b4	CH3 temperature lower than lower limit	CH3 normal
	b5	CH3 temperature higher than upper limit	CH3 normal
4	b6	CH4 temperature lower than lower limit	CH4 normal
	b7	CH4 temperature higher than upper limit	CH4 normal
Reserved	b8 ~ b15		

6. BFM#600: channel mode selection, used to set the working modes of CH1 ~ CH4. See Figure 2-1 for their correspondence.

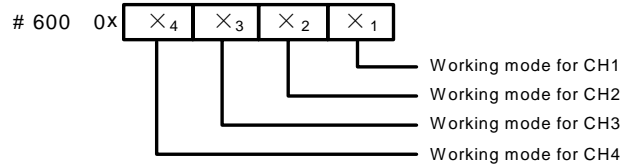

Figure 2-1 Mode setting element vs. channel

The exact meaning of the X in the channel mode is shown in Table 2-6. The conversion time of every channel is 240ms. When a channel is set closed, it will not perform AD conversion, thereby reducing the total conversion time.

Table 2-6 Meaning of X in channel mode

No.	X (hexadecimal)	Meaning
1	0	K type thermocouple. Digital signal unit: 0.1°C
2	1	K type thermocouple. Digital signal unit: 0.1°F
3	2	J type thermocouple. Digital signal unit: 0.1°C
4	3	J type thermocouple. Digital signal unit: 0.1°F
5	4	E type thermocouple. Digital signal unit: 0.1°C
6	5	E type thermocouple. Digital signal unit: 0.1°F
7	6	N type thermocouple. Digital signal unit: 0.1°C
8	7	N type thermocouple. Digital signal unit: 0.1°F
9	8	T type thermocouple. Digital signal unit: 0.1°C
10	9	T type thermocouple. Digital signal unit: 0.1°F
11	A	R type thermocouple. Digital signal unit: 0.1°C
12	B	R type thermocouple. Digital signal unit: 0.1°F
13	C	S type thermocouple. Digital signal unit: 0.1°C
14	D	S type thermocouple. Digital signal unit: 0.1°F
15	E	Channel closed
16	F	Channel closed

7. BFM#700 ~ BFM#703: average sampling times setting. Range: 1 ~ 256. If the setting is outside this range, the value will be reset to the default 8.

5. BFM#900 ~ BFM#915: channel characteristics setting data register. Use two points to define the channel characteristic. D0 and D1 are the channel digital output, in the unit of 0.1°C. A0 and A1 are the actual temperature input of the channel, also in the unit of 0.1°C. Each channel occupies 4 words.

You can change the channel characteristic by changing D0 and D1. The setting range of D0 is -1000~1000 (0.1°C); D1, 11,000~13,000 (0.1°C). If the setting is outside this range, EC10-4TC will not accept it, but maintain the original valid setting.

Note that the characters are all in 0.1°C unit. Convert Fahrenheit parameters as per the following formula before using them in the characteristic setting:

$$\text{Celsius} = 5/9 \times (\text{Fahrenheit} - 32)$$

9. BFM#4094: software version information, displayed automatically as **Module Version in EC10-4TC Configuration** dialogue box of the host software, as shown in Figure 4-1.

10. BFM#4095: module ID. The ID of EC10-4TC is 0x4041. The PLC user program can use this code to identify the module before transceiving data.

3 Characteristic Setting

The input channel characteristic of EC10-4TC is the linear relationship between the channel's analog input A and digital output D. It can be set by the user. Each channel can be considered as the model shown in Figure 3-1. As it is of linear characteristic, the channel characteristic can be defined by just two points: P0 (A0, D0) and P1 (A1, D1), where D0 is the channel's digital output corresponding to analog input A0, and D1 is the channel's digital output corresponding to analog input A1.

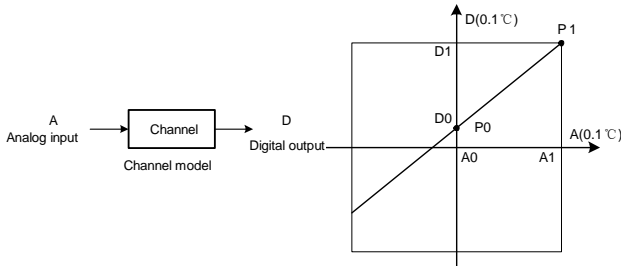

Figure 3-1 EC10-4TC channel characteristic setting

The channel characteristic setting is used to correct the onsite linear error in EC10-4TC measurement caused by the different ambient temperatures and compensation cables.

To simplify the operation process without affecting functions, A0 and A1 are respectively fixed to 0 and 12,000 (unit: 0.1°C) in the present mode. That is to say, the A0 and A1 in Figure 3-1 are respectively 0 and 12,000 (unit: 0.1°C). Users cannot change their values.

If you just set the channel mode without changing D0 and D1, the channel characteristic vs. 0 mode should be as shown in Figure 3-2.

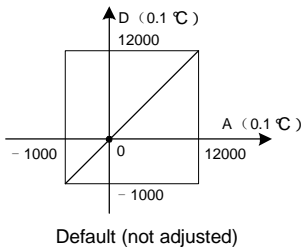

Figure 3-2 Characteristic vs. 0 mode without changing D0 and D1

Note that when the mode is set to 1 or 3, the output will be in 0.1°F unit, and the temperature data read from the output data zone will be in 0.1°F unit. But the data in the channel characteristic setting zone will still be in 0.1°C unit, which means the data in the channel characteristic setting zone is always in 0.1°C unit. Keep this in mind when changing D0 and D1.

You can change the characteristics by changing D0 and D1. The setting range of D0 is -1000~1000 (0.1°C); D1, 11000~13000 (0.1°C). If the setting is outside this range, EC10-4TC will not accept it, but maintain the original valid setting. Figure 3-3 provides you an example of changing K type and J type thermocouple characteristic when the EC10-4TC measured value is 5°C (41°F) higher the actual value.

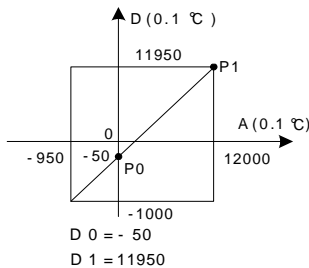

Figure 3-3 Changing characteristic

4 Application Example

4.1 Basic Application

Example: Connect channels 1 and 2 of EC10-4TC respectively to K and J type thermocouples with Celsius output, connect channel 3 to K type thermocouples with Fahrenheit output, and close CH4. Set the average sampling times of CH1 ~ CH3 to 4, and use data registers D1 ~ D3 to receive the average value.

The setting interface of output CH1 is shown in Figure 4-1. After the setting, click the downward arrow button ▼ to continue to set CH 2 ~ CH4, whose setting interfaces are shown in figures 4-2 ~ 4-4. For detailed software usage, see *EC20/10 Series PLC Programming Manual*.



Figure 4-1 CH1 setting interface



Figure 4-2 CH2 setting interface



Figure 4-3 CH3 setting interface



Figure 4-4 CH4 setting interface

4.2 Changing Characteristics

Example: Connect CH1 of EC10-4TC to K thermocouple with Celsius output, connect CH2 to J type thermocouple Fahrenheit output. Close

CH3 and CH4. Set characteristics of channels 1 and 2 as per Figure 3-3. Set the average sampling times to 4 and use registers D1 and D2 to receive the average value.



Figure 4-5 Changing CH1 characteristic



Figure 4-6 Changing CH2 characteristic



Figure 4-7 Changing CH3 characteristic



Figure 4-8 Changing CH4 characteristic

2. Check that the extension cable of EC10-4TC is properly inserted in the extension port.
3. Check that the 5V and 24V power supplies are not overloaded. Note: The digital circuit is powered by the basic module through extension cable.
4. Check the application, make sure the operation method and parameter range are correct.
5. Set the EC10 basic module to RUN state.

5.2 Inspection Upon Fault

In case of abnormality, check the following items:

- The status of the POWER indicator
 - ON: the extension cable is properly connected;
 - OFF: check the extension cable connection and the basic module.
- The wiring of analog input
- The status of the 24V indicator
 - ON: 24Vdc power supply normal;
 - OFF: 24Vdc power supply possibly faulty, or EC10-4TC faulty.
- The status of the RUN indicator
 - Flash quickly: EC10-4TC in normal operation;
 - Flash slowly or OFF: Check the **Error Status** in **EC10-4TC Configuration** dialogue box through the host software.

Notice

1. The warranty range is confined to the PLC only.
2. **Warranty period is 18 months**, within which period Emerson Network Power conducts free maintenance and repairing to the PLC that has any fault or damage under the normal operation conditions.
3. **The start time of warranty period is the delivery date of the product**, of which the product SN is the sole basis of judgment. PLC without a product SN shall be regarded as out of warranty.
4. Even within 18 months, maintenance will also be charged in the following situations:
 - Damages incurred to the PLC due to mis-operations, which are not in compliance with the User Manual;
 - Damages incurred to the PLC due to fire, flood, abnormal voltage, etc;
 - Damages incurred to the PLC due to the improper use of PLC functions.
5. The service fee will be charged according to the actual costs. If there is any contract, the contract prevails.
6. Please keep this paper and show this paper to the maintenance unit when the product needs to be repaired.
7. If you have any question, please contact the distributor or our company directly.

ENP Services China
Emerson Network Power Co., Ltd.

Address: No.1 Kefa Rd., Science & Industry Park, Nanshan District
518057, Shenzhen China
Homepage: www.emersonnetworkpower.com.cn
E-mail: support@emersonnetwork.com.cn

Version V1.0
Revision date August 24, 2006
BOM 31011367

Copyright © 2006 by Emerson Network Power Co., Ltd.

All rights reserved. The contents in this document are subject to change without notice.

5 Operation Inspection

5.1 Routine Inspection

1. Check that the wiring of analog input meets the requirements (see 1.3 Wiring).