

# EC20 Series PLC Passive I/O Extension Module User Manual



## Warning

Before using the EC20 series PLC product, please carefully read the operation instructions and safety precaution in order to reduce the chance of accident. Only adequately trained personnel shall install or operate this product. In operation, strict compliance with applicable safety rules in the industry, the operating instructions and safety precautions in this book is required.

This manual focuses on the hardware specifications, features and usage of EC20 PLC extension module. As for the usage and programming method of the PLC itself, you can refer to Emerson *EC20 Series PLC User Manual*, *EC20 Series PLC Programming Manual* and *ControlStar Programming Program User Manual*. Please consult with the supplier when necessary.

## 1 General Description

### 1.1 Appearance

The appearance of EC20 series Passive I/O extension module is shown in the following figure.

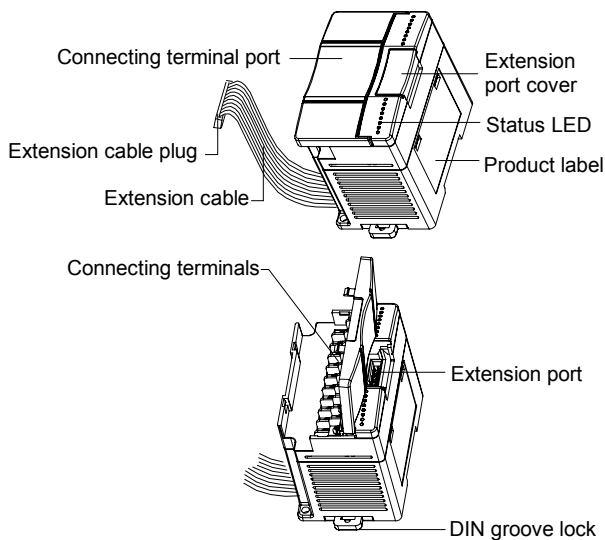

Figure 1-1 Appearance of extension module

## 1.2 Model Description

The model description is shown in the following figure.

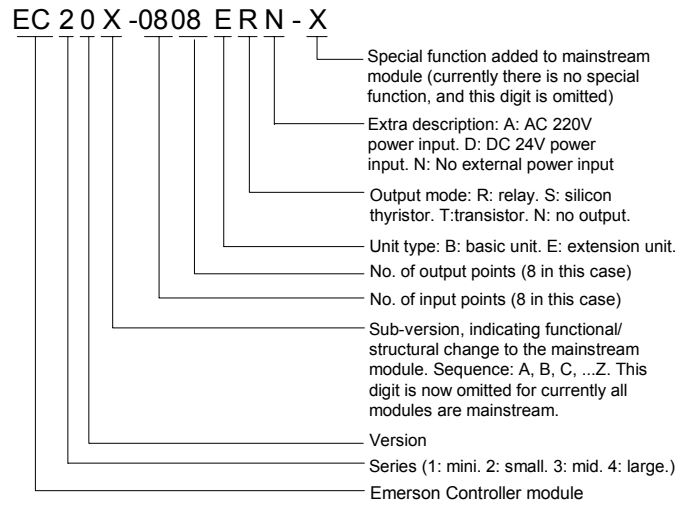

Figure 1-2 Model description

## 2 Installation

### 2.1 Sizes

The dimensions of the passive I/O extension module are shown below.

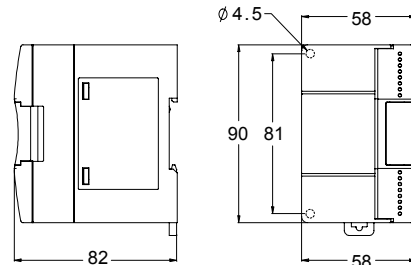

Figure 2-1 I/O extension module dimensions (unit: mm)

### 2.2 Installation

The installation method is the same as that of the basic module. For details, refer to *EC20 Series PLC User Manual*. See the following figures for the installation.

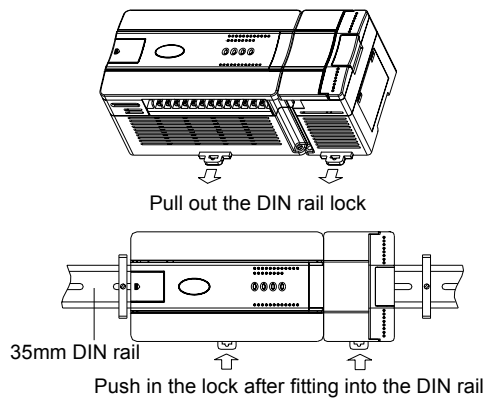

Figure 2-2 Fixing on DIN rail

### 3 Product Specification

Table 3-1 Extension module type and configuration

Type	Supply voltage Vac	Input/output points	Output type
EC20-0800ENN	/	8/0	/
EC20-1600ENN	/	16/0	/
EC20-0808ERN	/	8/8	Relay
EC20-0808ETN	/	8/8	Transistor
EC20-0016ERN	/	0/16	Relay
EC20-0016ETN	/	0/16	Transistor

Table 3-2 Insulation specifications of EC20 series PLC

Name	Specifications
User output (relay mode) to extension bus	Able to withstand 50Hz, 2300Vac or equivalent DC voltage for one minute without breakdown or flashover and with leakage current not more than 30mA
User input to user output (relay mode)	Able to withstand 50Hz, 2300Vac or equivalent DC voltage for one minute without breakdown or flashover and with leakage current not more than 30mA
User input terminal to extension bus	SELV circuit requirements are met

Table 3-3 Power requirements of extension module

Model	DC5V/GND	DC24V/GND	DC24V/COM
EC20-0800ENN	50mA	/	45mA
EC20-0808ERN	50mA	50mA	50mA
EC20-0808ETN	130mA	/	45mA
EC20-1600ENN	75mA	/	90mA
EC20-0016ERN	65mA	75mA	/
EC20-0016ETN	190mA	/	/

Note:

- 1) DC5V/GND: The working power of the logical circuit of the extension module comes from the extension bus
- 2) DC24V/COM: The input status sensing power is led in through the "24V" terminal
- 3) DC24V/GND: The working power of the relay circuit of the extension module comes from the extension bus

Before connecting the extension module to the PLC, to prevent the basic module from being overloaded, you should:

1. Add up the current consumption of all power loops of the extension module.
2. Make sure the current consumption of each power loop of the extension module is smaller than the output current the corresponding power source of the basic module can provide.

The solution to insufficient power supply is to select an active extension module. Besides providing power for itself, it can provide power to the extension modules added later through its 5Vdc, 24Vdc/GND and 24Vdc/COM terminals.

### 4 Input Characteristics

#### 4.1 Internal Equivalent Input Circuit

The extension module should be connected to external user switch status sensing power (24Vdc). The internal equivalent resistance of its input circuit is approximately 4.3kΩ. The signal sensing adopts bi-directional optical coupling, and the signal input can be source or sink type. You only need to connect dry contact switch signals. If you need to connect output signals of active transistor sensors, they should be OC output signals. The IO extension module's internal equivalent power and input signal connections resemble the mains module's input circuit, as shown in Figure 4-1.

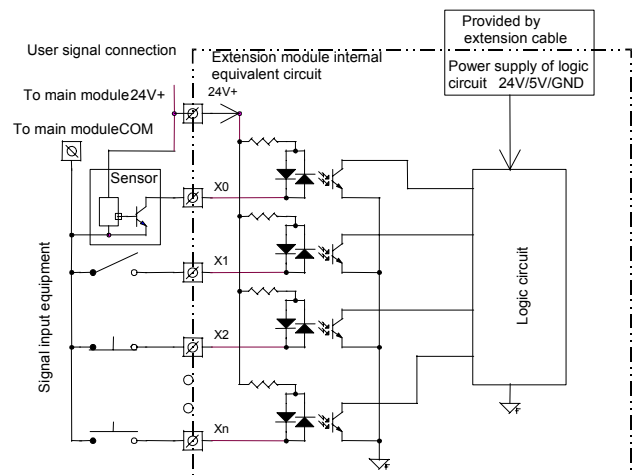

Figure 4-1 Internal equivalent input circuit

## 4.2 I/O Status Indication

The input status LEDs indicate the status of the user input port. It is on when the input port is closed (ON), and off otherwise.

The output status LEDs indicate the status of the output port. It is on when the output port is closed (ON, with pin Yn connected to pin COMn), and off otherwise. See the following figure.

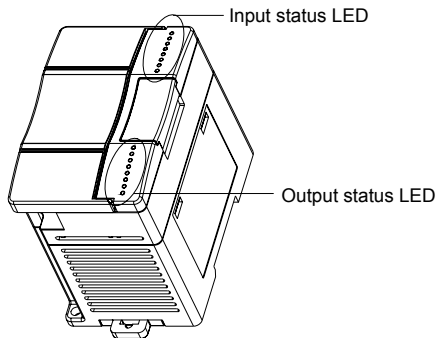

Figure 4-2 Status LEDs of EC20 series extension module

## 5 Output Characteristics

### 5.1 Electrical Specifications Of Relay Output Port

Table 5-1 Electrical specifications of relay output port

Item	Relay output port	
Voltage	250Vac, below 30Vdc	
Circuit insulation	Relay physical insulation	
Action indication	LED turns on when the relay output contact is closed	
Open circuit leakage current	/	
Min. load	2mA/5Vdc	
Max output current	Resistive load	2A/1 point. The total current of the 8 points sharing COM port should be smaller than 8A
	Inductive load	220Vac, 80VA
	Electric light load	220Vac, 100W
ON response time	20ms Max	
OFF response time	20ms Max	

### 5.2 Electrical Specifications Of Transistor Output Port

Table 5-2 Electrical specifications of transistor output port

Item	Transistor output port
Voltage	5 ~ 24Vdc
Circuit insulation	Optical coupling insulation
Action indication	The LED turns on when the optical coupling is driven

Item	Transistor output port	
Open circuit leakage current	< 0.1mA/30Vdc	
Min. load	5mA (5 ~ 24Vdc)	
Max output current	Resistive load	0.3A/1 point, 0.8A/4 points; 1.6A/8 points; above 8 points, each point can add 0.1A to total current
	Inductive load	24Vdc, 7.2W
	Electric light load	24Vdc, 1.5W
ON response time	≤ 0.5ms (100mA/24Vdc)	
OFF response time	≤ 0.5ms (100mA/24Vdc)	

### 5.3 Output Connection Example

Figure 5-1 shows the connection between EC20-3232BRA and EC20-0808ERN. Different output groups can connect to different signal voltage loops. Some output groups (like Y0-COM0) can connect to +24Vdc loop and can be supplied by 24V/COM of the EC20 PLC, some (like Y1-COM1) can connect to +5Vdc low voltage signal loop; while others (like Y2~Y7) can connect to 220Vac signal loop. That is to say, the output groups can work at different voltage levels.

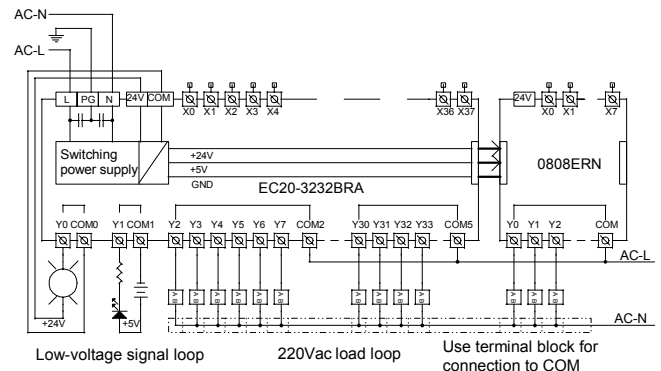

Figure 5-1 EC20-3232BRA and EC20-0808ERN connection

## 6 Extension Connection

### 6.1 Connecting Extension Bus

Power off the basic module, remove the cover of the extension port at the right end of the basic module, insert the extension cable of the extension module into this port, and restore the cover. If you need to connect more extension modules, just connect them one by one using the same method.

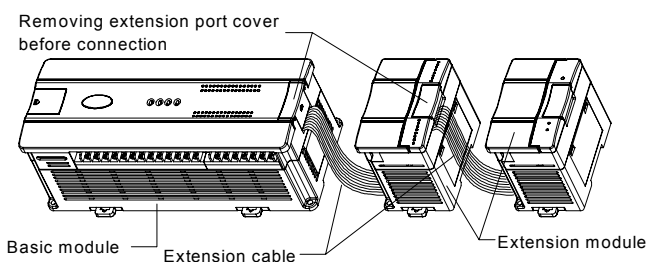

Figure 6-1 Cascade connection of extension modules

## 6.2 Addressing Extension Module

EC20 series PLC can automatically identify and address the connected extension modules in sequence, with no need of user interference.

The automatic addressing is performed once and for all after power-on, and the address will not change afterwards in operation. When the PLC is in operation, it is not allowed to connect or disconnect any IO extension modules or special functional modules, as which may cause damage or malfunction to the PLC.

The active extension module must be powered on at the same time as or before the basic module, so as to ensure reliable addressing.

The IO point coding adopts octal coding, i.e., 0, 1, 2, 3, 4, 5, 6, 7, 10, 11, 12, 13, 14, 15, 16, 17, 20, 21, ..., no 8 or 9.

The input port coding of the basic module and IO extension module is: X0, X1, X2, ...X7, X10, X11, ...; their output port coding is: Y0, Y1, Y2, ...Y7, Y10, Y11, ...and so on. In coding, the input ports are grouped in eights, the part falling short of eight are kept vacant.

Take the EC20-2012BRA module as an example, the input has 20 points, the coding is from X0 to X23, terminals from X24 to X27 do not exist, the X terminals of the extension modules added later start from X30; likewise, the output has 12 points, the coding is from Y0 to Y13, terminals from Y14 to Y17 do not exist, the Y terminals of the extension modules added later start from Y20.

The X and Y terminals of the IO extension modules are coded in the sequence they are added into the system.

Example of logic coding of the basic module's and extension module's ports:

EC20-2012BRA	0808E TN	1600ENN	4AD	4AD	4DA	0016ERN	4TC
X0 -X23	X30- X37	X40- X47	0	1	2	Y30 -Y37	3
Y0 -Y13	Y20- Y27	X50- X57				Y40- Y47	

## Notice

1. The warranty range is confined to the PLC only.
2. **Warranty period is 18 months**, within which period Emerson Network Power conducts free maintenance and repairing to the PLC that has any fault or damage under the normal operation conditions.
3. **The start time of warranty period is the delivery date of the product**, of which the product SN is the sole basis of judgment. PLC without a product SN shall be regarded as out of warranty.
4. Even within 18 months, maintenance will also be charged in the following situations:
  - Damages incurred to the PLC due to mis-operations, which are not in compliance with the User Manual;
  - Damages incurred to the PLC due to fire, flood, abnormal voltage, etc;
  - Damages incurred to the PLC due to the improper use of PLC functions.
5. The service fee will be charged according to the actual costs. If there is any contract, the contract prevails.
6. Please keep this paper and show this paper to the maintenance unit when the product needs to be repaired.
7. If you have any question, please contact the distributor or our company directly.

ENP Services China

Emerson Network Power Co., Ltd.

Address: No.1 Kefa Rd., Science & Industry Park, Nanshan District 518057, Shenzhen China

Homepage: [www.emersonnetworkpower.com.cn](http://www.emersonnetworkpower.com.cn)

E-mail: [support@emersonnetwork.com.cn](mailto:support@emersonnetwork.com.cn)

Version V1.2

Revision date August 24, 2006

BOM 31011270

Copyright © 2006 by Emerson Network Power Co., Ltd.

All rights reserved. The contents in this document are subject to change without notice.